

16kWh energy storage battery pack--JK BMS

All batteries use CALB's new A-grade
314Ah LiFePO4 cells



UserManual

1. Product description	5
1.1 Product dimension	5
1.2 Product details	6
1.3 Technical specification	7
2. BMS characteristics	9
2.1 Dip switch Setings	10
2.2 Interface board Interface definition	10
2.3 LED description	12
2.4 Insturctions for using the parallel function	13
2.4.1 DIP switch setting example	13
2.4.2 Dual machine parallel connection diagram	16
2.4.3 Multi-machine parallel connection diagram	17
3. BMS parameter setting instructions	18
3.1 Power on/off	18
3.2 Screen language settings	18
3.3 Adjust the communication protocol via the screen	19
3.4 Device Connection	21
3.4.1 Search and Bluetooth connection for multiple devices	22
3.4.2 BMS parameter settings	23

Standing energy storage battery pack



Standing energy storage battery pack

- Equipped with silent wheels for easy mobility
- 51.2V, 320Ah, ultra-large capacity
- Dual ports, support parallel expansion
- A-grade super lithium iron phosphate cells for an extremely long life
- JK-BMS, compatible with multiple protocols

Lying Stackable Home Storage Battery Pack



Lying Stackable Home Storage Battery Pack

- Equipped with silent wheels for easy mobility
- 51.2V, 320Ah, ultra-large capacity
- Dual-port, stackable, and convenient parallel expansion
- A-grade super lithium iron phosphate cells for an extremely long life
- JK-BMS compatible with multiple protocols

1.Product description

1.1 Product dimension

Model	Size(L*W*H)
16kWh JK-BMS Standing	410*275*805mm
16kWh JK-BMS Lying	410*730*270mm
Outer box size	280*490*470mm

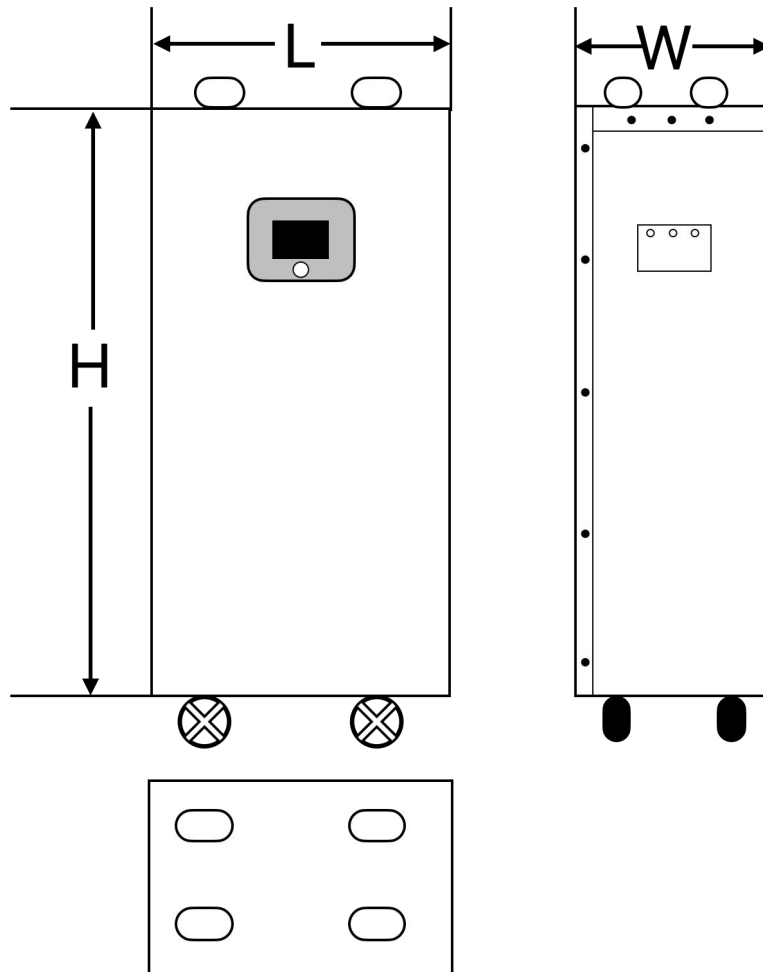

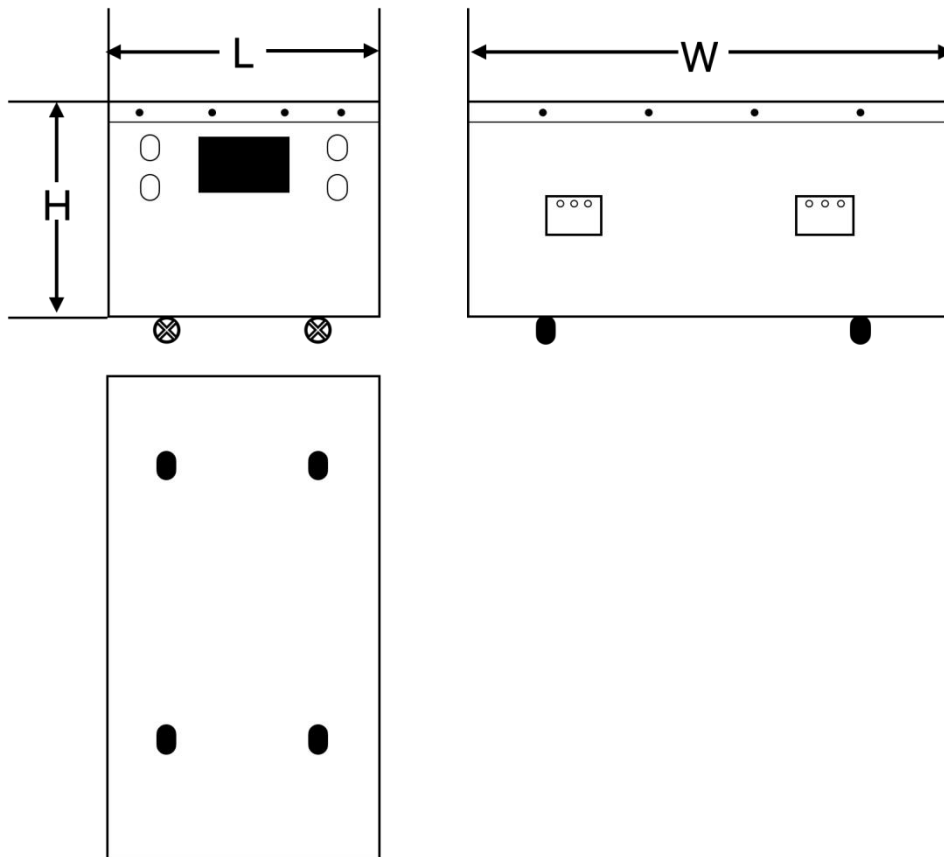

1.2 Product details

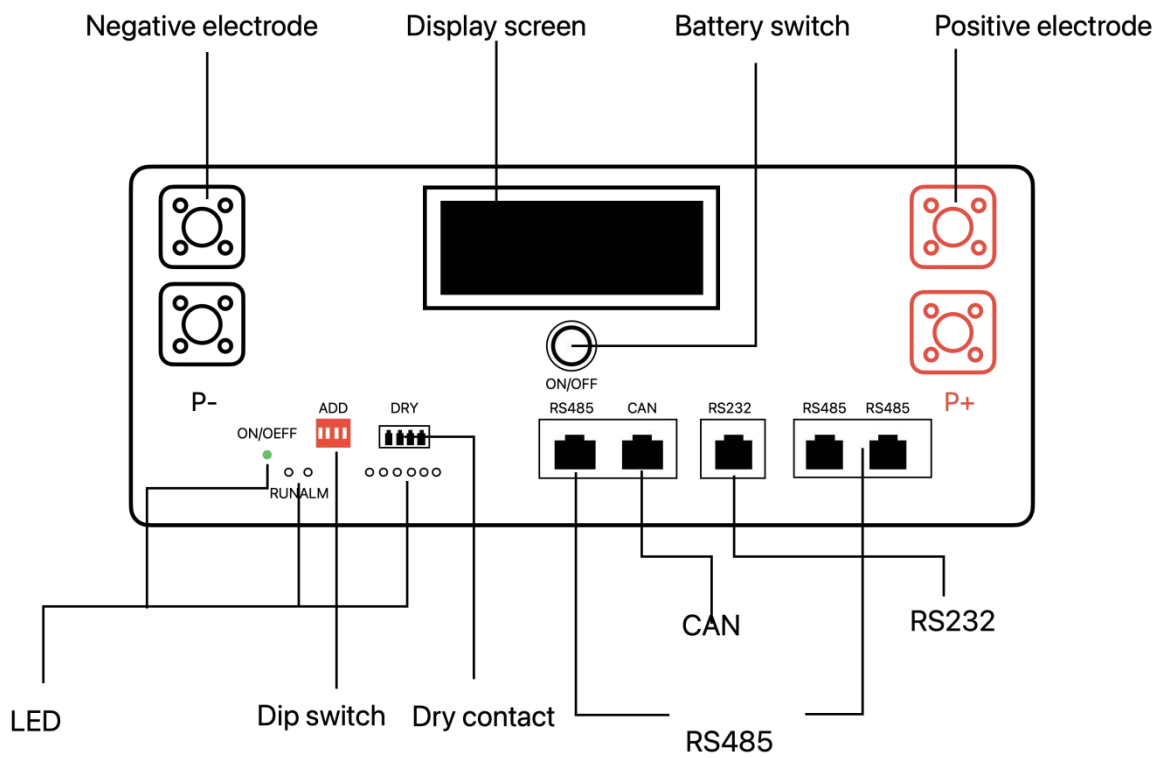

1.3 Technical specification

16kWh JK-BMS Standing

No.	Project	Specification
1	Model	16kWh Standing energy storage battery pack
2	Nominal Capacity	320AH
3	Nominal Voltage	51.2V
4	Charging Voltage	56.8-57.6V
5	Operating Voltage	40V~58.4V
6	Charging Standard Current	0.2C
7	Maximum Charging Current	0.5C
8	Standard Charging Mode	At a temperature of 25°C, charge to 58.4V with a constant current of 0.2C 5A, and then charge continuously with a constant voltage of 58.4V until the current is not greater than 0.02C 5A.
9	Maximum Discharge Current	1C
10	Charging Temperature	0°C to 45°C (32°F to 113°F) @10%~90% relative humidity
11	Discharge Temperature	-20°C to 60°C (-4°F to 140°F) @10%~90% relative humidity
12	Storage Temperature	-20°C to 60°C (-4°F to 140°F) @10%~90% relative humidity
13	Size	410/275/805MM
14	Net Weight Approx	119KG
15	Communication Protocol	RS485、RS232、CAN
16	Support Inverter Brand	Growatt、Deye、Goodwe、Voltronicpower、Sofar、VICTRON、Solis、Megarevo、SRNE

16kWh JK-BMS Lying

No.	Project	Specification
1	Model	16kWh Standing energy storage battery pack
2	Nominal Capacity	320AH
3	Nominal Voltage	51.2V
4	Charging Voltage	56.8-57.6V
5	Operating Voltage	40V~58.4V
6	Charging Standard Current	0.2C
7	Maximum Charging Current	0.5C
8	Standard Charging Mode	At a temperature of 25°C, charge to 58.4V with a constant current of 0.2C 5A, and then charge continuously with a constant voltage of 58.4V until the current is not greater than 0.02C 5A.
9	Maximum Discharge Current	1C
10	Charging Temperature	0°C to 45°C (32°F to 113°F) @10%~90% relative humidity
11	Discharge Temperature	-20°C to 60°C (-4°F to 140°F) @10%~90% relative humidity
12	Storage Temperature	-20°C to 60°C (-4°F to 140°F) @10%~90% relative humidity
13	Size	410/730/270MM
14	Net Weight Approx	120.5KG
15	Communication Protocol	RS485、RS232、CAN
16	Support Inverter Brand	Growatt、Deye、Goodwe、Voltronicpower、Sofar、VICTRON、Solis、Megarevo、SRNE

2. BMS characteristics

2.1 Dip switch Settings

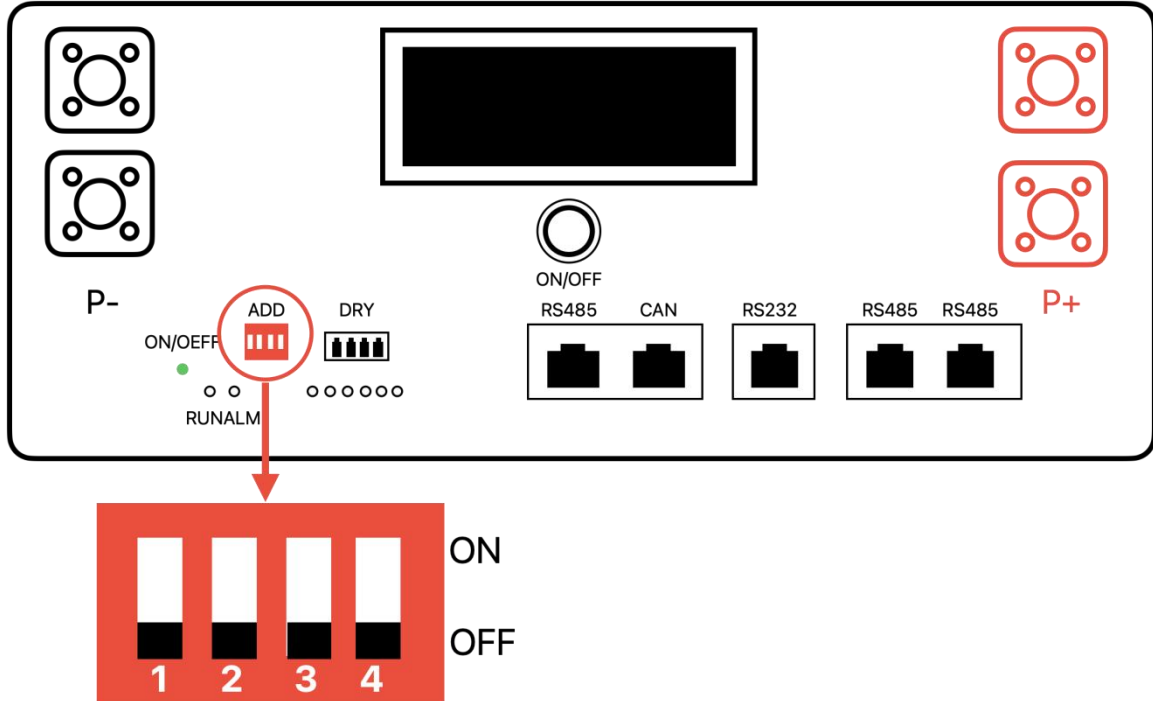

address	Dip switch position			
	1	2	3	4
0	OFF	OFF	OFF	OFF
1	ON	OFF	OFF	OFF
2	OFF	ON	OFF	OFF
3	ON	ON	OFF	OFF
4	OFF	OFF	ON	OFF
5	ON	OFF	ON	OFF
6	OFF	ON	ON	OFF
7	ON	ON	ON	OFF
8	OFF	OFF	OFF	ON
9	ON	OFF	OFF	ON
10	OFF	ON	OFF	ON
11	ON	ON	OFF	ON
12	OFF	OFF	ON	ON
13	ON	OFF	ON	ON
14	OFF	ON	ON	ON
15	ON	ON	ON	ON

2.2 Interface board Interface definition

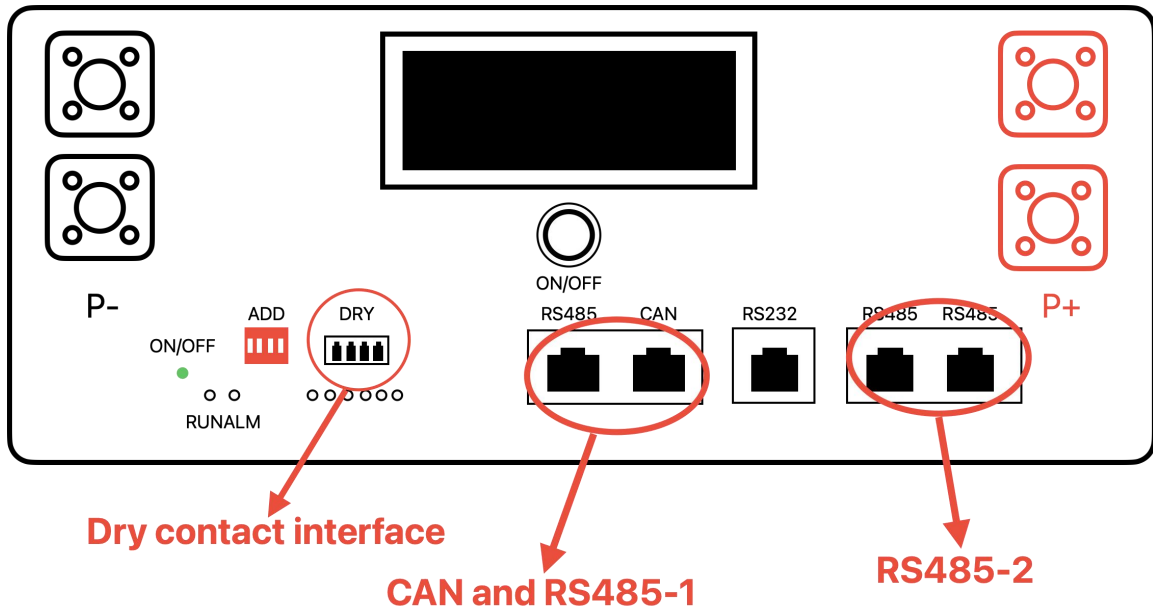

Definition of a dry contact interface	
Pin number	Pin definition
1	COM1
2	S1
3	COM2
4	S2

Interface definition of CAN and RS485-1	
Pin number	Pin definition
1, 8	RS485-B1
2, 7	RS485-B2
3, 6	GND
4, 5	NC

1, 2, 3, 4, 6, 8	NC
4	CANL
5	CANH
7	GND

Interface definition of RS485-2	
Pin number	Pin definition
1	RS485-B2
2	RS485-A2
3	GND
4	NC
5	NC
6	GND
7	RS485-A2
8	RS485-B2

Remark: If your inverter has a different pin out communication setting to our battery a custom cable should be made to communicate with our battery. Refer to your manufacturers manual for CAN RS485 pin outs or contact your manufacturer.

2.3 LED description

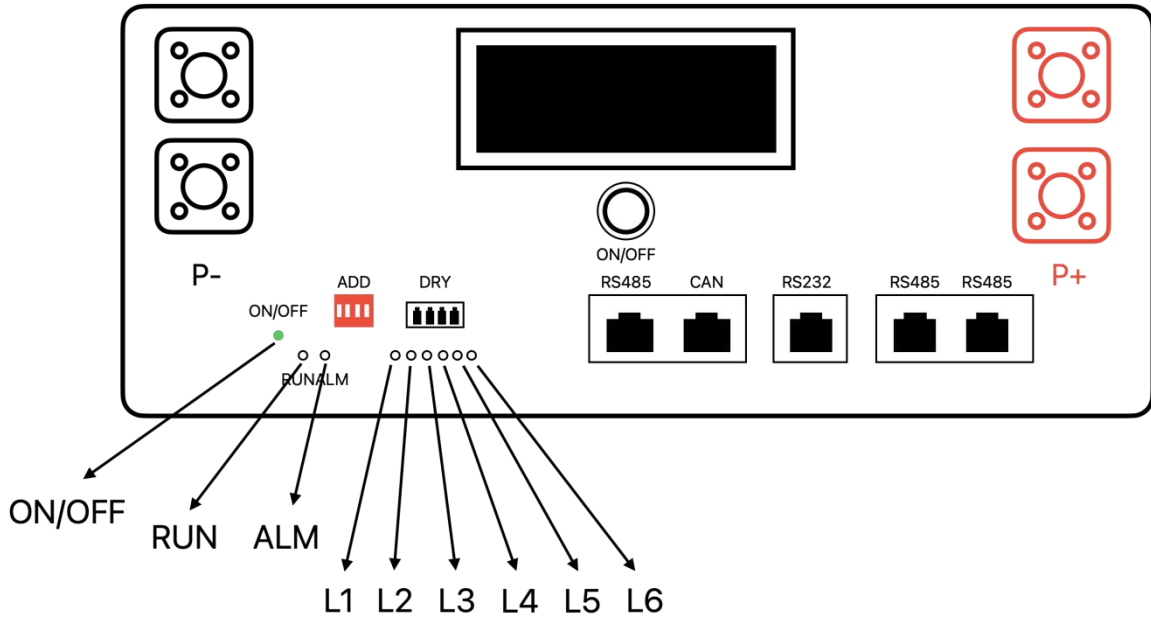

status	Normal alarm, or Protection	ON/OFF F	RUN	ALM	L1	L2	L3	L4	L5	L6
Power Off	normal	OFF								
Balance	normal	ON	flicker	OFF	Battery based display					OFF
charging	normal	ON	flicker	OFF	Battery based display					OFF
	Over current, over temperature, over voltage, charging failure	ON	flicker	flicker	Battery based display					OFF
discharge	normal	ON	flicker	OFF	Battery based display					OFF
	Over current, over temperature, over voltage, charging failure	ON	flicker	flicker	Battery based display					OFF
Other alarm	Password not changed/short circuit/temperature abnormal	ON	flicker	flicker	Battery based display					OFF

Note:When the device address is set to 0,the last LED indicator L6 blinks. If the value is set to other values, the slave is off and blinks after the communication between the slave and the host is successful

2.4 Insturctions for using the parallel function

The parallel function refers to the use of multiple energy storage series protection boards to achieve simultaneous monitoring of multipel BMS information by the upper compiter through the RS485 bus. Therefore, the tools required to use the parallel function include USB to RS485 serial port cable and Jikong upper computer.

The parallel function supports up to 16 BMS, so it is necessary to set address for each BMS. There are a total of 16 BMS with address ranging form 0 to 15. BMS with address 0 is the host, and BMS 1 to 15 is the slave. The upper computer is connected to the host through a USB to RS485 serial port calb, and the BMS address is set through a dip awitch. The specific setting method is show in 2.1-Dip switch Setting.

2.4.1 DIP switch setting example

Example of Host Address 0 Setting



Example of Setting Slave Address 1



Example of Setting Slave Address 2



Example of Setting Slave Address 3



Example of Setting Slave Address 15



2.4.3 Multi-machine parallel connection diagram

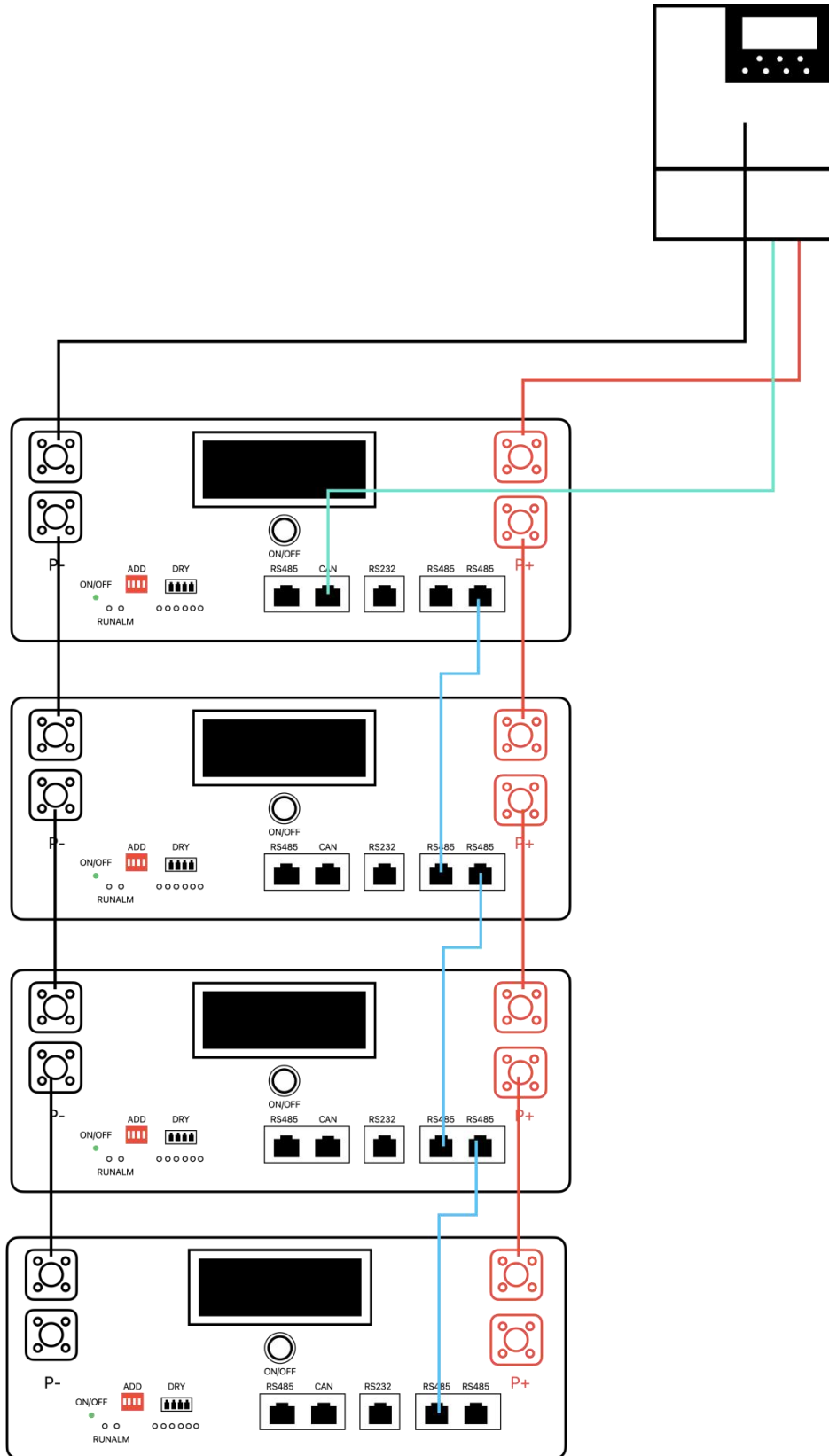

3. BMS parameter setting instructions

3.1 Power on/off

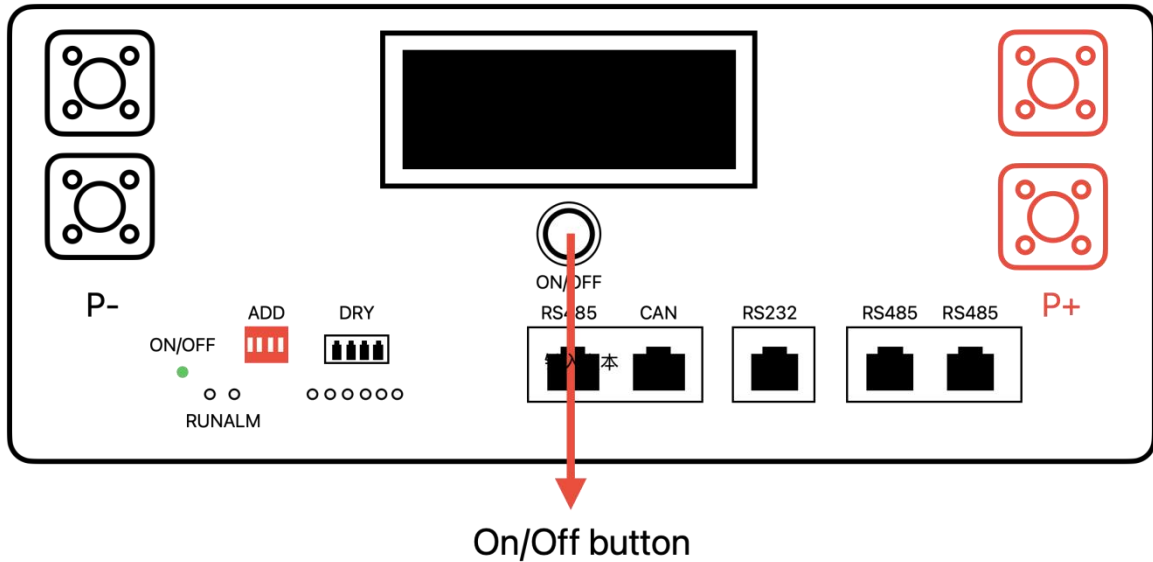

Press and hold for 1 second to power on after a beep.

Press and hold for 5 seconds to turn off the phone after the screen goes off.

3.2 Screen language settings

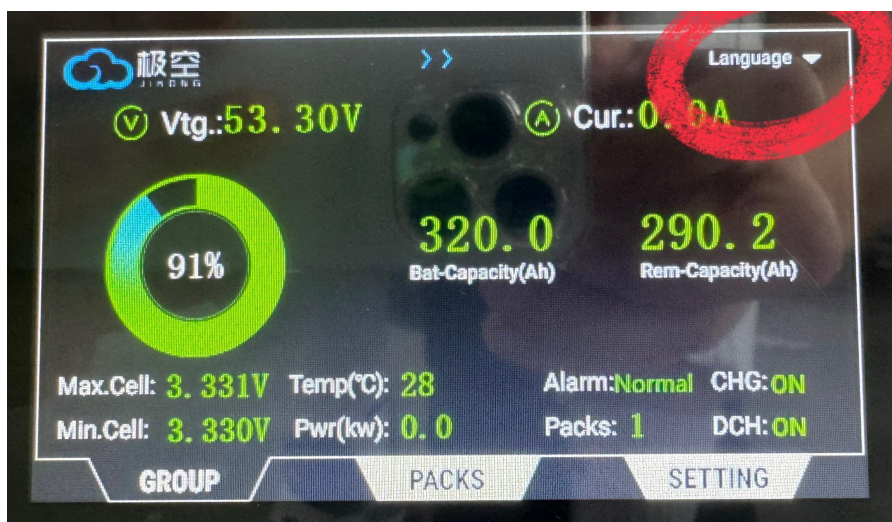

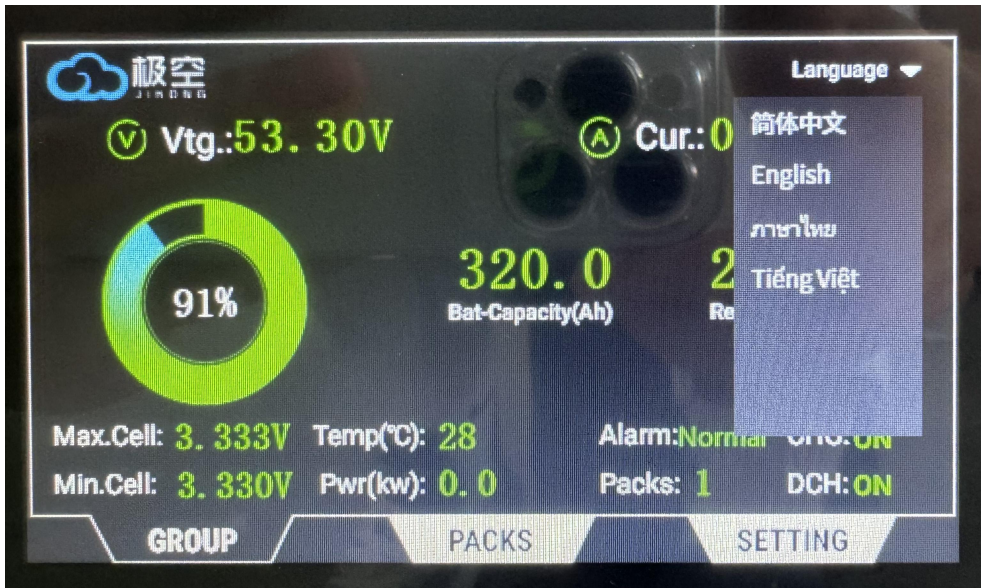

After the battery is turned on, click on the upper right corner of the screen to set the language

3.3 Adjust the communication protocol via the screen

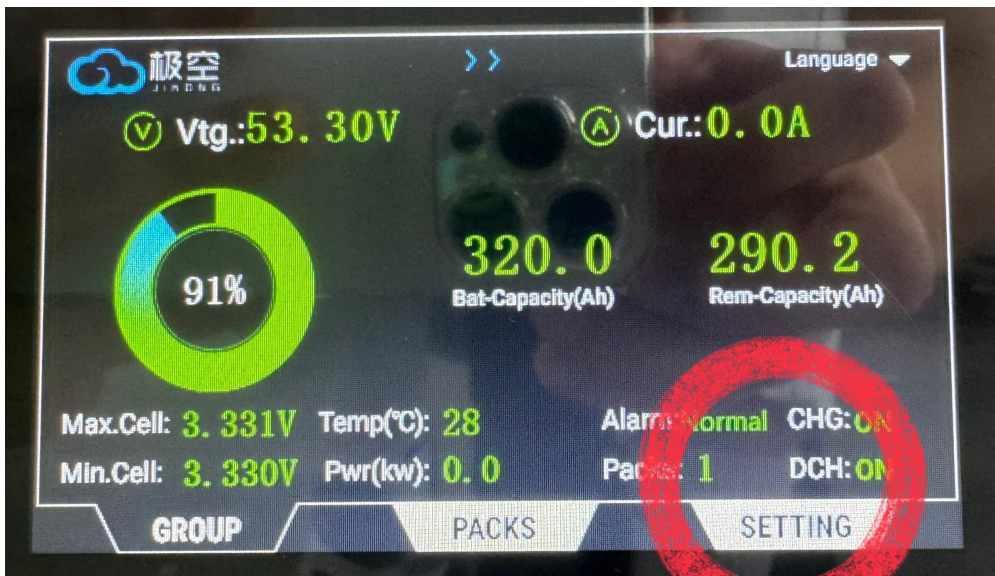

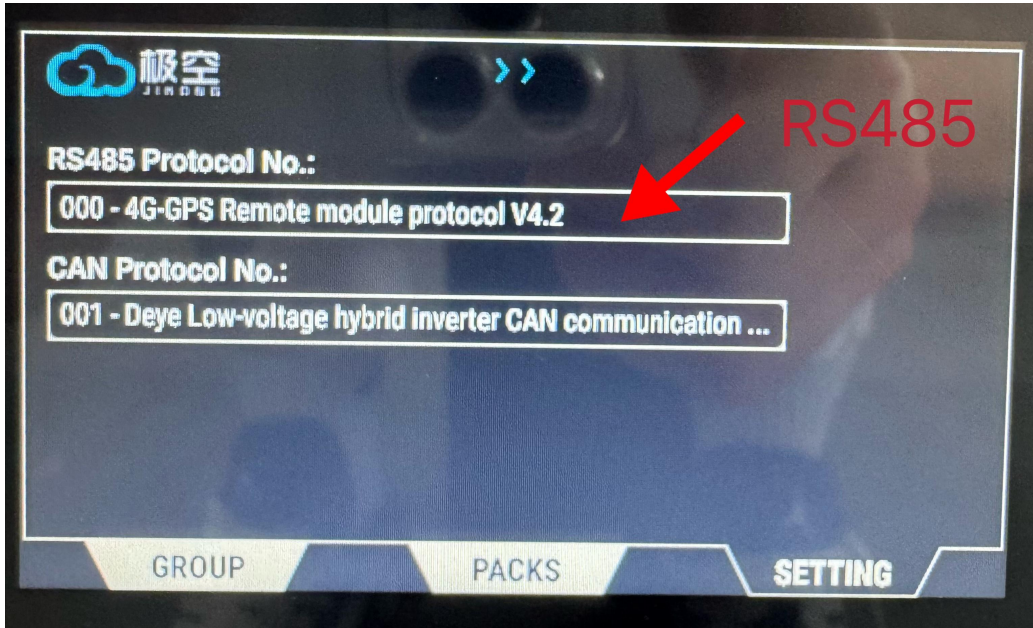

Adjust RS485 communication protocol to achieve parallel communication of different brands of BMS

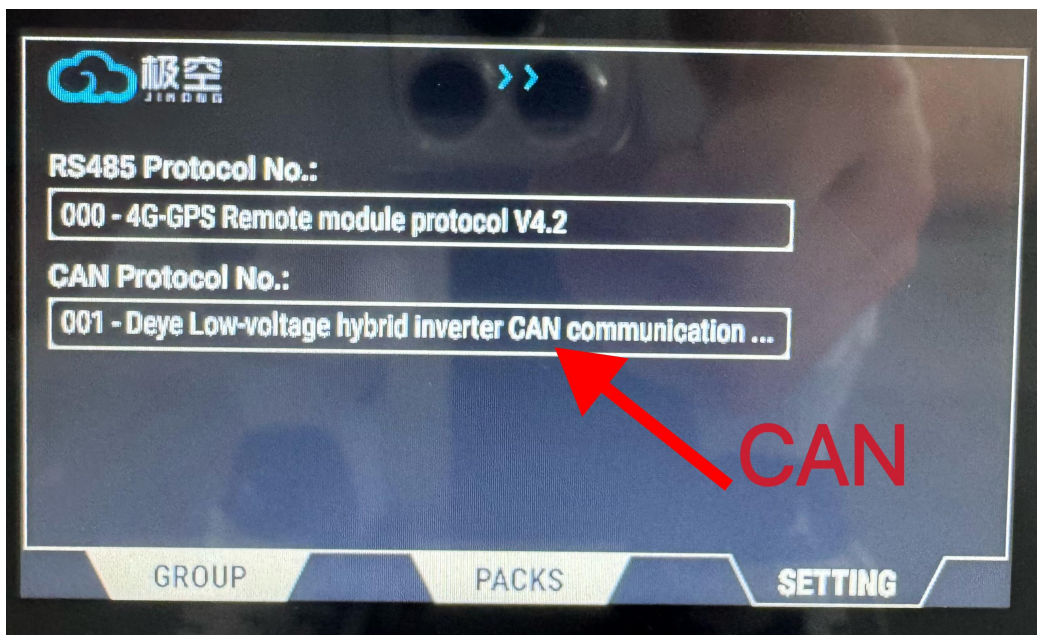

Adjust the CAN protocol to achieve communication with different inverters.

3.4 Device Connection

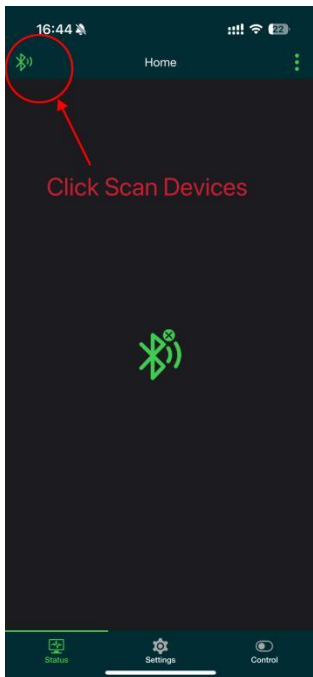

Figure 1 Device Scan



Figure 2 Select the device

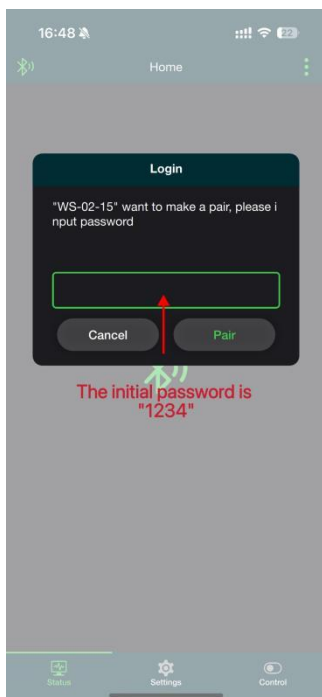

Figure 3 Enter password

Turn on your phone's Bluetooth and open the app, as shown in Figure 1. Tap the icon in the upper left corner to scan for devices. After the scan is complete, tap the name of the device you want to connect to, such as "WS-02-15."

The app will prompt you for a password the first time you connect. The default password for the device is "1234."

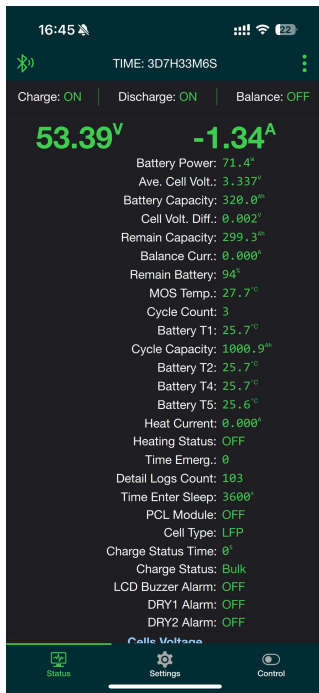

Figure 4 Entering the device information interface

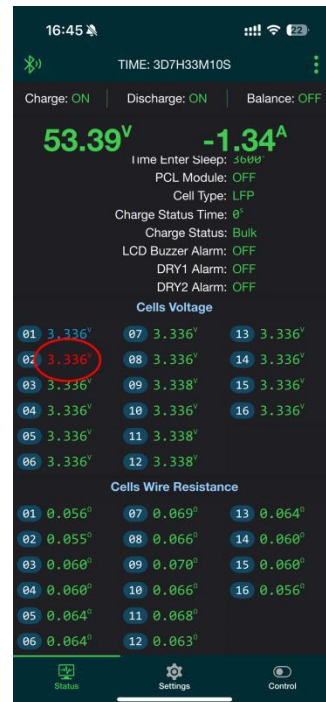
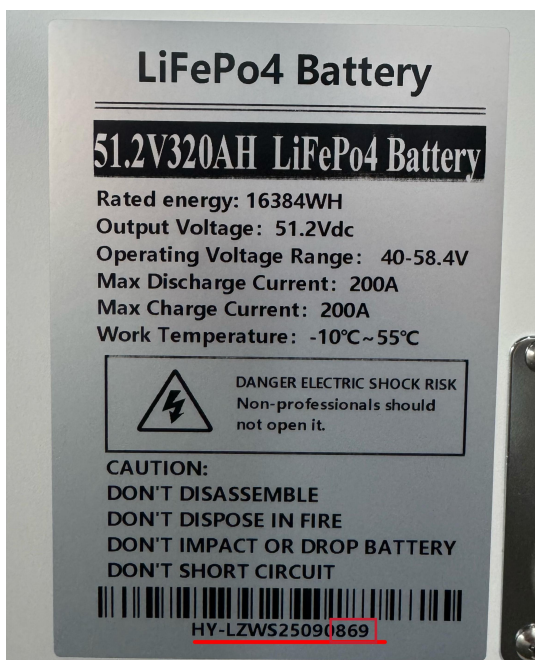
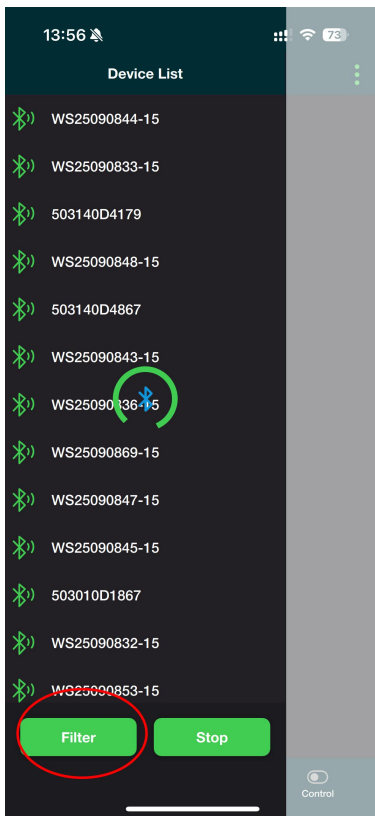

Figure 5 shows red values indicating that the BMS is balancing the voltage

3.4.1 Search and Bluetooth connection for multiple devices



The device number is marked on the battery shell



Search by the last three digits of the number

3.4.2 BMS parameter settings

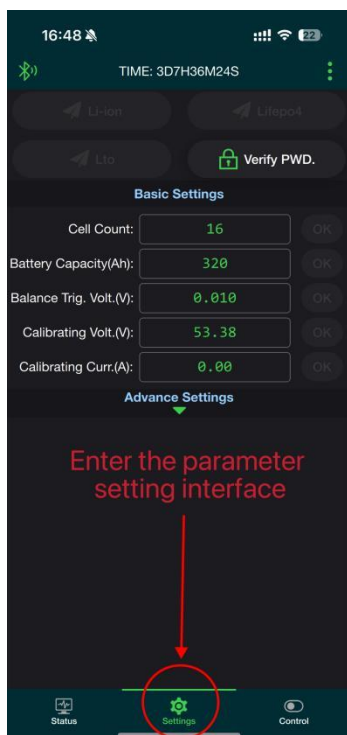

Figure 1 Entering the parameter setting interface
Figure 2 Click the Authorization Settings button

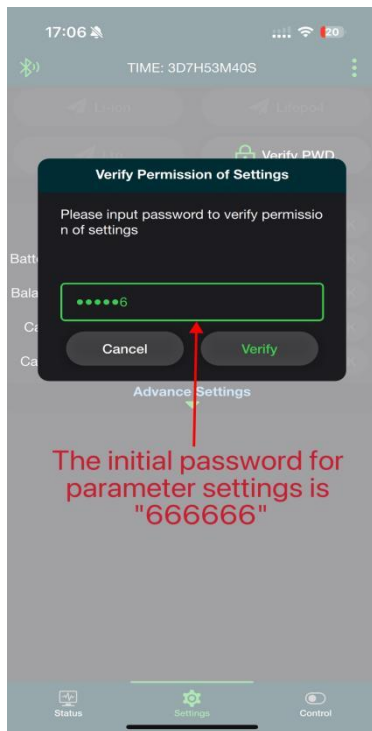

Figure 3 The initial password for parameter settings is "666666"

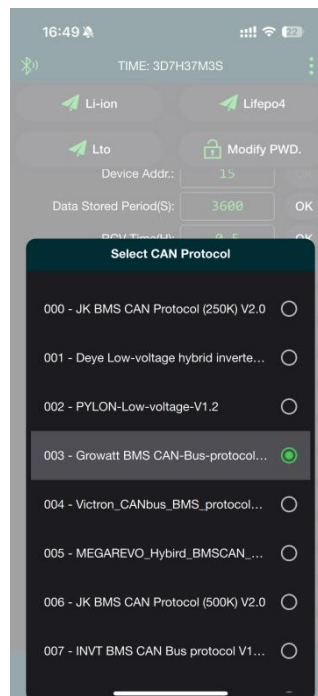
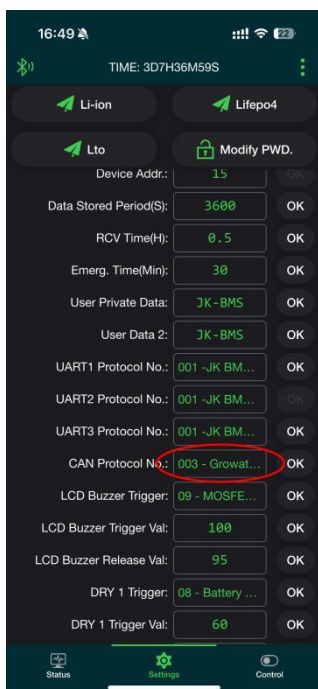













Figure 4, 5 Scroll down the parameter setting interface to find the inverter brand you want to communicate with, select the corresponding protocol and save the settings.

极空BMS-PB系列通讯协议逆变器列表汇总(CAN)

逆变器品牌		协议名称	通信接口	真机调试	匹配型号	协议在逆变器代码
德业 Deye		低压储能CAN通信协议 Low-voltage hybrid inverter CAN communication protocol	CANBUS-500K	是	SUN-5K-SG03LP1-EU	1.Battery Setup Menu->Lithium 2.Advanced Function->BMS_Err_Stop
派能 PYLON		派能CAN总线协议V1.2 PYLON CANBUS Protocol V1.2	CANBUS-500K	否		
		派能低压RS485通信协议 PYLON low voltage RS485 Protocol				
古瑞瓦特 Growatt		古瑞瓦特低压CAN总线协议REV_05 Growatt BMS CAN-Bus-protocol -low-voltage_Rev_05	CANBUS-500K	是	SPF 3000TL HVM-48	1.在05中设LI 2.在36中设置为1, 则为CAN通信
		储能机与电池PACK之间RS485通讯协议V2.01 Growatt xxSxxP ESS Protocol V2.01	RS485-9600	是	SPF 3000TL HVM-48	1.在05中设LI 2.在36中设置为51, 则为RS485通信
维克多 Victron		维克多CAN总线协议201707 CAB-BUS_BMS_Protocol_201707	CANBUS-500K	是	Cerbo GX	
英威腾 Invent		英威腾户用储能逆变器低压版BMS通信协议(V1.02) INVT BMS CAN Bus protocol V1.02	CANBUS-500K	是	BD5KTL-RL1	
固德威 GoodWe		固德威低压CAN总线协议V1.7(ES/EM/S-BP/BP系列) GoodWe LV BMS Protocol (CAN) V1.7(For ES/EM/S-BP/BP Series)	CANBUS-500K	是	GW5000-ES-20	电池类型中选择GoodWe->SECU-A5.4L*1
SMA		SMA电池与逆变器通信协议 FSS-ConnectingBat-TI-en-10 Version 1.0	CANBUS-500K	否		
日月元 Voltronic		日月元逆变器与BMS RS485通信协议 Voltronic Power Inverter and BMS 485 communication protocol	RS485-9600	否		1.长按SET键进入设置页面; 2.将05项设置成LIB;
硕日 SRNE		硕日Modbus通信协议 PACE BMS Modbus Protocol for RS485	RS485-9600	是	HF2430S60-100	1.将39设置成BMS 2.将32设置成BMS 3.将33设置成WOW
美世乐 MUST						
首航						

JK-BMS mobile app download

